

A Zigbee Based Wireless Datalogging System

Author: Arun Kumar

Abstract

This paper is designed using embedded technology. Typically, an embedded system is housed on a single microprocessor or microcontroller board with the programs stored in it. Microcontroller is more preferred to microprocessor as it contains all the features of a computer including central processor, in-built clock circuitry, ROM, RAM, input and output ports with special features viz. serial communication, analogue-to-digital conversion etc. This work is about developing a prototype of microcontroller based data logger which can be used in both wireless and wired technology. The wireless technology we used is a new, advanced and improved technology named Zigbee, which is an IEEE802.15.4

standard.. Here in place of 1 sensor could be used 8 sensors at the 8 channel of ADC0809. Zigbee is far better than compared to any other wireless technology available like Bluetooth, wifi. Zigbee is designed to consume very low power which is cost-effective and provides a wide range like 100m. In this paper peer to peer-communication topology is established. But star or mesh topology can be used; and in mesh topology by increasing the number of routers the range can be increased (>100m). Therefore it can be used in home automation, industrial automation, and light link, health care and in many other fields.

Keywords: Zigbee, Data logging, Embedded, LM358

1. Introduction

A Wireless Sensor Network is a wireless sensor infrastructure for collecting, synthesizing, distributing, viewing, and reacting to information. While a Wireless Sensor Network is well suited to collecting data in hazardous or inhospitable locations, the system has considerable value when situational monitoring must be accomplished over an extended area over a period of time. The Sensor Network can provide situational awareness in many types of applications including disaster preparedness and recovery, emergency response, temperature recording and monitoring etc. Uses of a Sensor Network are virtually limitless since different types of sensors can be connected to the system for different functionalities. Here, the primary

Application focus will be that related to recording the temperature and monitoring of its variations. A Wireless Sensor Network is an embedded, intelligent infrastructure

for sensors. The processes to collect, analyze and store the data for later use is called logging. A data logger is an electronic instrument that can record digital or analog measurements over a

Period of time. It consists of a sensor, microcontroller, and a data storage device. Data loggers have an on-board memory that is large enough to hold data that is recorded over a longer period of time. The memory in these data loggers may be flash memory, EEPROM or Static Random Access Memory that is battery backed. Data loggers are provided with real-time clocks to record the date and time of acquisition. This entire work is about the development of a prototype of Microcontroller based data logging system which can work on wired and wireless network. The testing has been done on wireless network using Zigbee technology.

2. Objective:

The main objective of this work is to develop a microcontroller based wireless Data logging System. Zigbee will be used as the wireless technology.

The entire work is executed in three different phases:

i) In phase I, a Temperature/Humidity sensor will be connected to an ADC (Analog to Digital Converter). ADC will be interfaced With the Microcontroller. The sensor data will be collected through ADC for digital conversion.

ii) In phase 2, the converted digital data will be taken and processed by the Microcontroller itself. After processing the microcontroller will send the data through Zigbee transmitter module to the Zigbee receiver module attached to the computer.

iii) In Phase 3, another Zigbee receiver device will collect the data and send the data to computer via Com Port. A simple application will run to show the actual sensor data like Temperature Humidity etc.

3. Experimental methodology/design

A Block diagram is given below to describe our proposed work

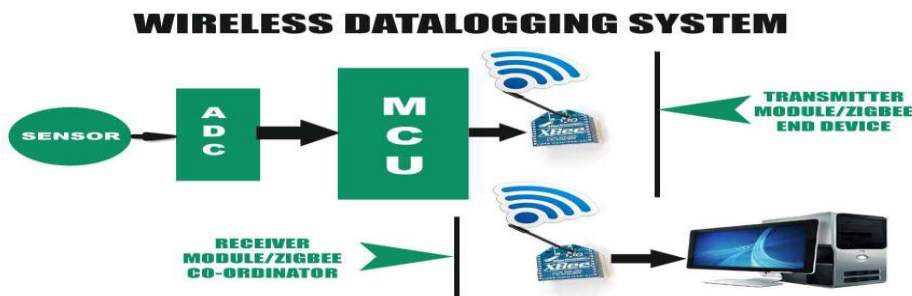
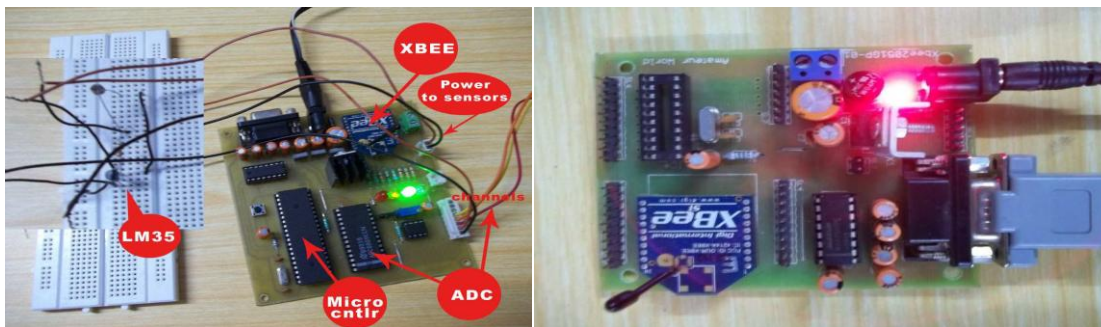

Figure 1. Showing the typical component of wireless datalogging system,



Transmitter

Receiver

Figure 2. Indicating the component of wireless datalogging system on which the present work has been performed.

The LM35 sensor circuit is given.

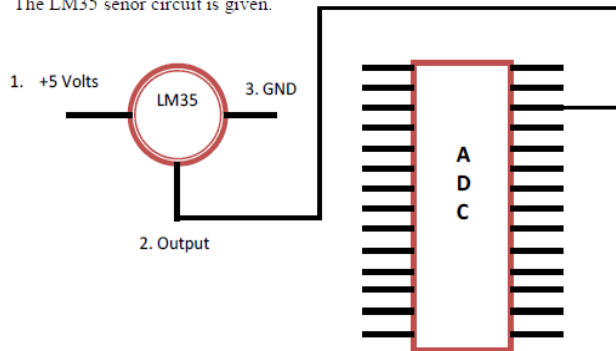

Fig3. Interference of LM35 (sensor) with ADC.

Technology used:

1. Embedded Technology
2. Wireless Technology (Zigbee)
3. LM358

3.1 Embedded Technology

An embedded system is one that has computer-hardware with software embedded in it as one of its most important component. It is a dedicated computer-based system for an Application or product. It may be either an independent system or a part of a larger system. As its software usually embeds in ROM (Read Only Memory) it does not need secondary memories as in a computer.

Zigbee/IEEE 802.15.4 - General Characteristics:

- Dual PHY (2.4GHz and 868/915 MHz)
- Data rates of 250 kbps (@2.4 GHz), 40 kbps (@ 915 MHz), and 20 kbps (@868 MHz)
- Optimized for low duty-cycle applications (<0.1%)
- CSMA-CA channel access
- Low power (battery life multi-month to years)
- Multiple topologies: star, peer-to-peer, mesh
- Addressing space of up to:
 - 18,450,000,000,000,000 devices (64 bit IEEE address)
 - 65,535 networks
- Range: 50m typical (5-500m based on environment)

3.3 LM35:

3.2 Zigbee Technology: Zigbee is the only standards-based wireless technology designed to address the unique needs of low-cost, low-power wireless sensor and control networks in just about any market. Since ZigBee can be used almost anywhere, is easy to implement and needs little power to operate, the opportunity for growth into new markets, as well as innovation in existing markets, is limitless.

LM 35 has been used as the temperature sensor. It generates an output voltage proportional to the temperature of the surroundings. In practice output Voltage increases by 10mV by every 1 degree increment in temperature. Hence if we observe the output voltage to be 200mV at some time, we can say that the temperature at that moment is 20 degree Celsius. The output of the sensor is connected as the input of the ADC..The ADC upon proper interfacing with the microcontroller would give a digital output corresponding to the temperature. This digital output is transmitted using the XBEE wireless module. At a central computer node, the transmitted data is received in the hyper terminal and displayed to the general user.

3.4 Software Used:

- (1) Kiel Micro version 2.
- (2) Flash Magic

(3) X CTU

- (1) Automotive, transportation.
- (2) Acoustic, sound, vibration
- (3) Flow, fluid velocity
- (4) Chemical
- (5) Electric current, electric potential, magnetic, radio
- (6) Optical, light, imaging, photon
- (7) Environment, weather, moisture, humidity. Etc

3.5 Application:

IT can used be used in following area as a sensor:

Figure4. Shows Application Interface

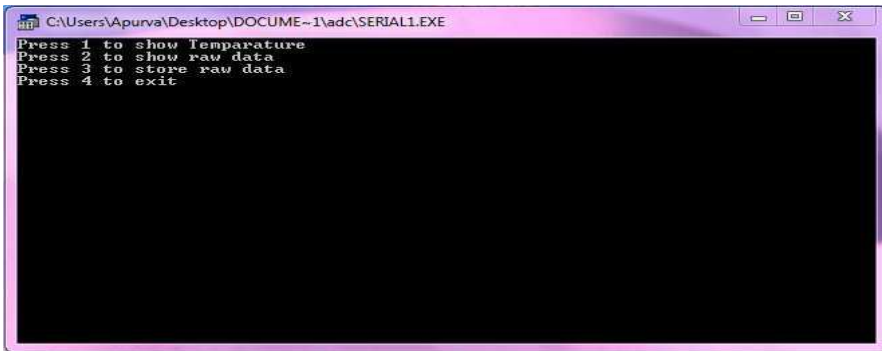

Figure5.Shows display of Temperature

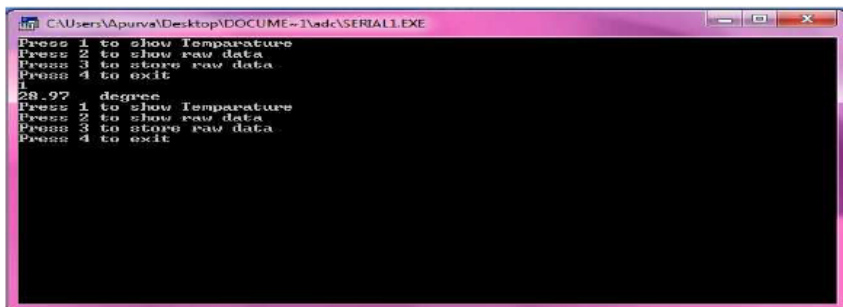
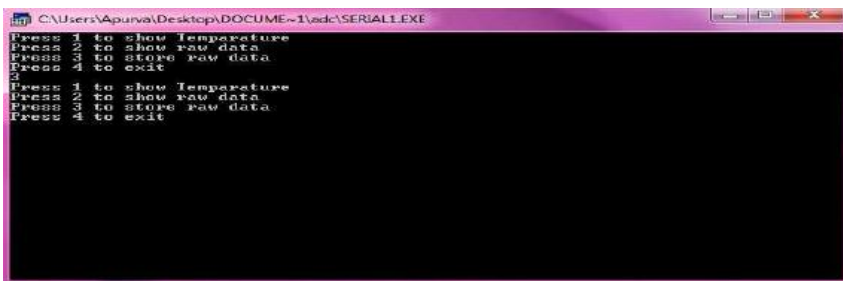

Figure6.Shows the Log data upon selection of option 3.



4. Discussions and Conclusion

Zigbee and Bluetooth are both wireless PAN technologies. But we have chosen Zigbee

Because Zigbee has some advantages over Bluetooth. The comparison between Zigbee and Bluetooth is given below:

	Bluetooth (v1)	ZigBee
Protocol Stack	250 kb	< 32 kb (4kb)
Range	10 - 100 meters	30 - 100 meters
Link Rate	1 Mbps	250 kbps
Battery	rechargeable	non-rechargeable
Devices	8	2 ¹⁶
Air Interface	FHSS	DSSS
Usage	frequently	infrequently
Network Join Time	long	short
Extendability	no	yes
Security	PIN, 64 bit, 128 Bit	128 bit, AES

Table.1 Comparison between Zigbee and Bluetooth

Exploration on Zigbee technology can enhance several aspects of the paper. Those are Given below:

- Inclusion of Zigbee routers may enhance the network size and range.
- Using Zigbee technology advance protocol programming, we can form cluster tree or Mesh networks
- We can use the XBEE module itself instead of MCU and ADC, as the XBee module Has MCU and ADC in built.

- We have tested with 2 sensors (1. LM35, 2. LDR), we can attach up to 8 sensors with this system.
- Zigbee has a limited range in outdoor i.e. 900 meters approx. If we want to increase the range of the transceiver we have to use XBee-Pro (1.5 Kms in LOS).
- ⊗ Wireless transmission and range partially depends on the weather condition, Temperature, humidity etc

5. References

(1). IEEE Standards 802, Part 15.4: Wireless Medium Access Control (MAC) and Physical Layer (PHY) specifications for Low Rate Wireless Personal Area Networks (LR-WPANs), IEEE, April 2003.

- (2) Zigbee document 053474r17, Zigbee specification release 17, Zigbee Technical Steering Committee.
- (3).Zigbee document 04319r01, Zigbee IEEE 802.15.4 PHY & MAC Layer Test Specification release r01, Zigbee Application Working Group.
- (4).Peatman, J.B. Design with microcontrollers and microcomputers, McGraw Hill.
- (5). Stewart.J.W.The8051MicrocontrollerHardware, Software and Interfacing Prentice Hall.

About author:

Arun Kumar,
Lecturer, Dept of E&C, EILM University, Sikkim, INDIA
Email id: arun.kumar1986@live.com
Phn no: +918927169377